

HR MOUNT SERIES:

Technical Data

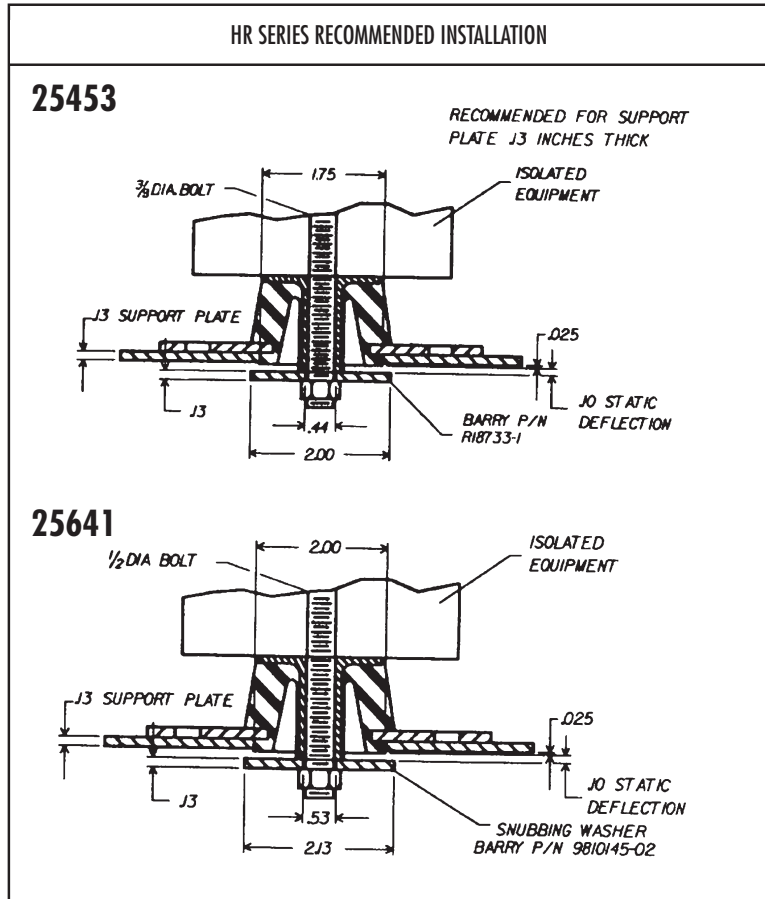

HR SERIES MAXIMUM TIGHTENING TORQUES (FT - LBS)			
Part #	Bolt Diameter	Torque (dry)	Torque (lubricated or plated)
25453	.375	45*	35*
25641	.500	120*	90*
* = GRADE 8 BOLT TORQUE			