

INDUSTRIAL CONICAL MOUNTS

Rugged, high load capacity mounts provide vibration, shock and noise protection

APPLICATIONS

- Cabs/platforms
- Engines
- Generator sets
- Transmissions
- Compressors
- Fuel tanks

FEATURES

- One piece bonded construction
- High load capacity
- Low natural frequency
- Non-linear stiffness
- Snubbing feature on bottom

BENEFITS

- Consistent performance
- Low cost installation
- Fail safe when used with recommended hardware
- Provides shock, vibration and noise attenuation
- Withstands high impact shock
- High static deflection in the axial direction

LOAD RANGE

- 3 styles with axial static load ratings up to 1,146 lbs. per isolator



Industrial Conical Mount Series Isolators are designed to withstand the rigors of heavy-duty vehicular applications, off-road equipment, large trucks and construction equipment. They provide shock, vibration and noise isolation and are designed for high impact applications.

Specifications

• Natural Frequency	10-14 Hertz
• Transmissibility at resonance	10
• Resilient Element	Natural Rubber
• Standard Materials	Sintered metal and cold-rolled steel
• Weight	See dimensional drawings

Environmental Data

- Natural Rubber elastomer has an operating temperature range of -40°F to +180°F (-40°C to +82°C).

INDUSTRIAL CONICAL MOUNT SERIES: 27327 & 27328

Dimensions & Performance Characteristics

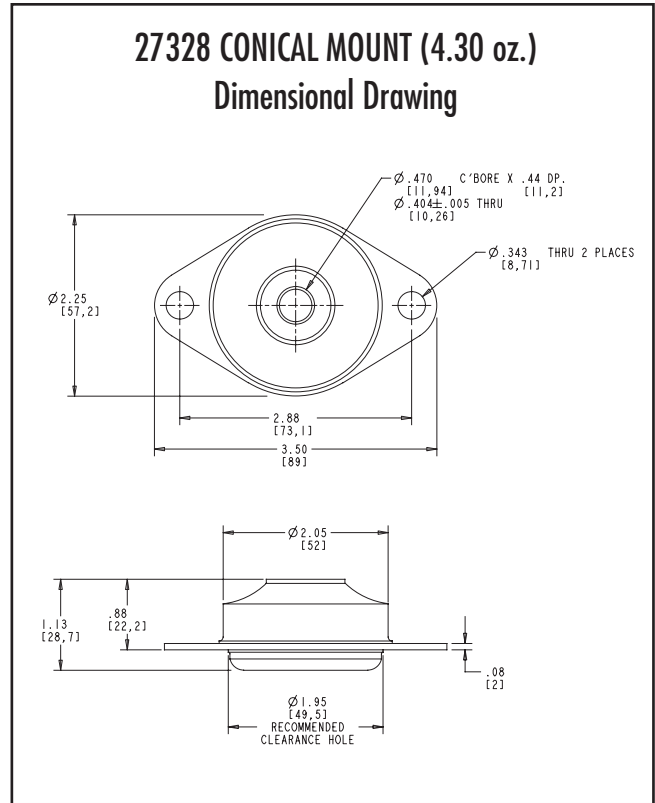
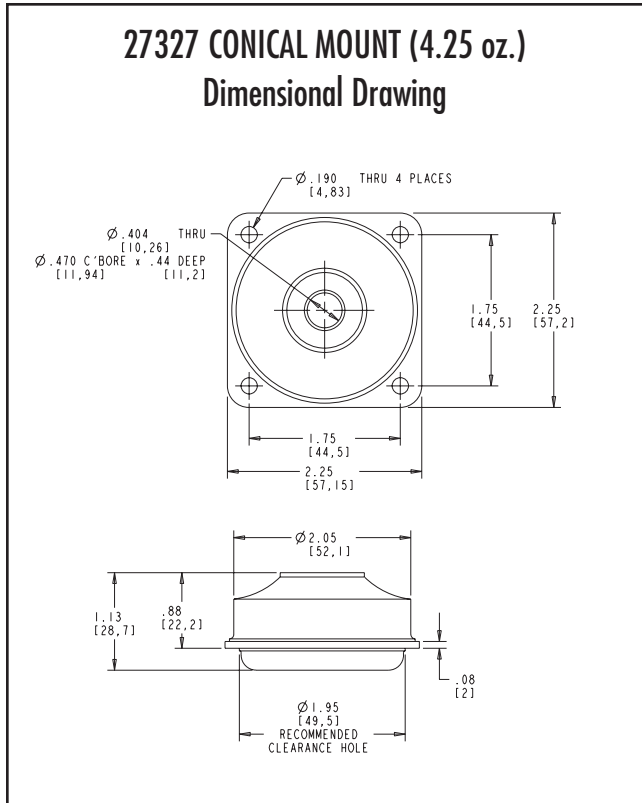

Part Number	Max. Axial Load Range (lbs.)	Color Code	Natural Frequency at Max. Load	Radial to Axial Stiffness Ratio	Bolt Size	Bolt Grade		Torque	
						SAE	ISO	ft-lbs	N-m
27327-45	82 lbs.	White	10 Hertz	2:1	3/8" or M10	8	10.9	50	76
27327-60	156 lbs.	Brown	10 Hertz	2:1	3/8" or M10	8	10.9	50	76
27327-70	233 lbs.	Orange	10 Hertz	2:1	3/8" or M10	8	10.9	50	76
27328-45	82 lbs.	White	10 Hertz	2:1	3/8" or M10	8	10.9	50	76
27328-60	156 lbs.	Brown	10 Hertz	2:1	3/8" or M10	8	10.9	50	76
27328-70	233 lbs.	Orange	10 Hertz	2:1	3/8" or M10	8	10.9	50	76

INDUSTRIAL CONICAL MOUNT SERIES: 26748

Dimensions & Performance Characteristics

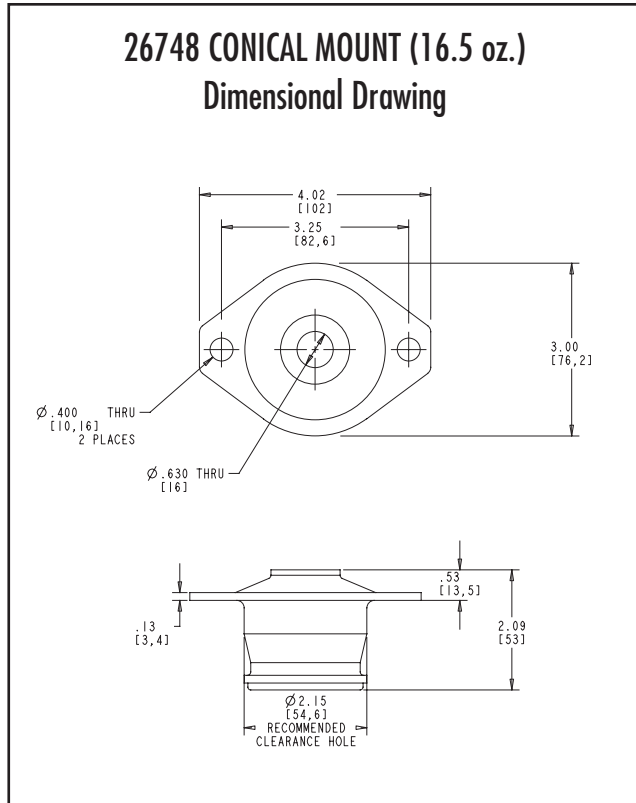

Part Number	Max. Axial Load Range (lbs.)	Color Code	Natural Frequency at Max. Load	Radial to Axial Stiffness Ratio	Bolt Size	Bolt Grade		Torque	
						SAE	ISO	ft-lbs	N-m
26748-45	286 lbs.	White	14 Hertz	4:1	5/8" or M16	5	8.8	180	235
26748-60	562 lbs.	Brown	14 Hertz	4:1	5/8" or M16	5	8.8	180	235
26748-70	750 lbs.	Orange	14 Hertz	4:1	5/8" or M16	5	8.8	180	235

INDUSTRIAL CONICAL MOUNT SERIES: 26749 & 27595

Dimensions & Performance Characteristics

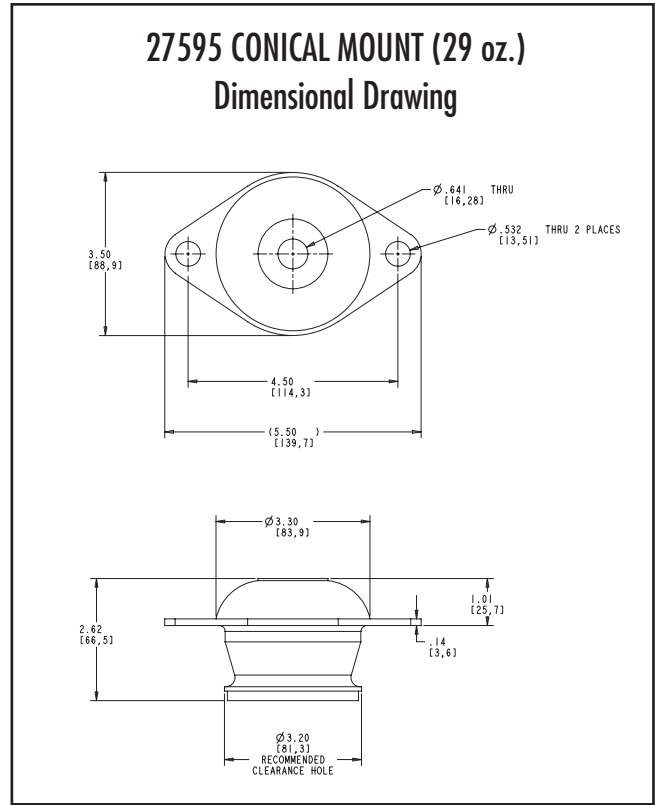
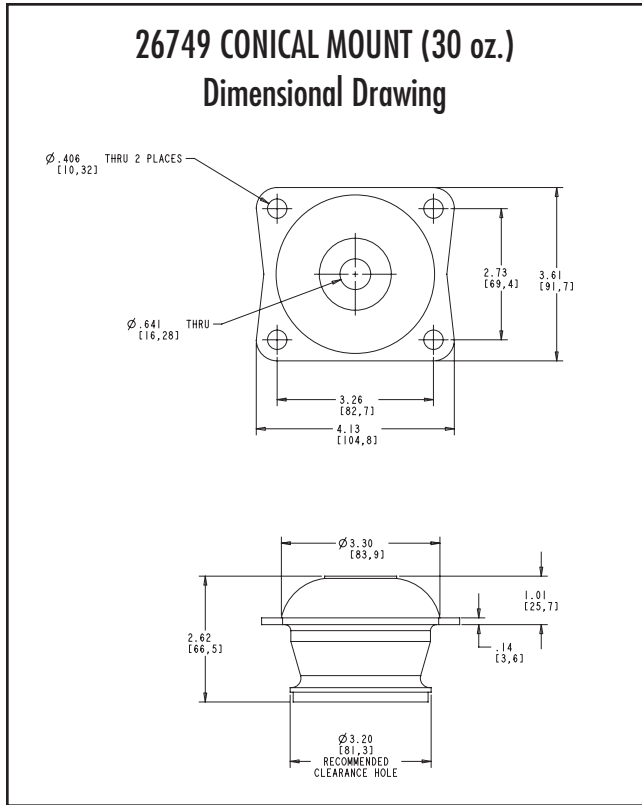

Part Number	Max. Axial Load Range (lbs.)	Color Code	Natural Frequency at Max. Load	Radial to Axial Stiffness Ratio	Bolt Size	Bolt Grade		Torque	
						SAE	ISO	ft-lbs	N-m
26749-45	463 lbs.	White	12 Hertz	1.5:1	5/8" or M16	5	8.8	180	235
26749-60	860 lbs.	Brown	12 Hertz	1.5:1	5/8" or M16	5	8.8	180	235
26749-70	1,146 lbs.	Orange	12 Hertz	1.5:1	5/8" or M16	5	8.8	180	235
27595-45	463 lbs.	White	12 Hertz	1.5:1	5/8" or M16	5	8.8	180	235
27595-60	860 lbs.	Brown	12 Hertz	1.5:1	5/8" or M16	5	8.8	180	235
27595-70	1,146 lbs.	Orange	12 Hertz	1.5:1	5/8" or M16	5	8.8	180	235

INDUSTRIAL CONICAL MOUNT SERIES: SNUBBING WASHERS

Dimensions & Selection Guide

INDUSTRIAL CONICAL MOUNT SERIES SNUBBING WASHER

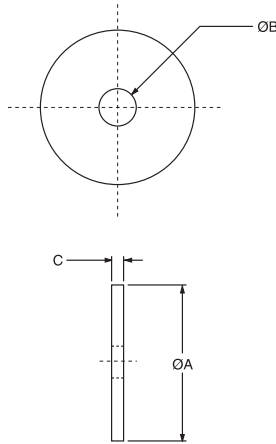

The use of snubbing washers is recommended to ensure proper static and dynamic loading of the isolator and retention of suspended equipment under severe shock environments.

Snubbing washers are ordered by separate part numbers as shown in the below table. The standard material is low-carbon steel and the standard finish is zinc plate. Other materials and finishes are available upon request.

Part Number	Head Washer Part Number	Part Dimensions (Inches)			Tail Washer Part Number	Part Dimensions (Inches)		
		A	B	C		A	B	C
27327	9810276-05804	2.25	0.52	0.125	9810276-05804	2.25	0.52	0.125
27328	9810276-05804	2.25	0.52	0.125	9810276-05804	2.25	0.52	0.125
26748	9810276-07804	2.50	0.64	0.125	9810276-06804	2.25	0.64	0.125
26749	9810276-12804	4.60	0.64	0.25	9810276-10804	3.50	0.64	0.19
27595	9810276-12804	4.60	0.64	0.25	9810276-10804	3.50	0.64	0.19

INDUSTRIAL CONICAL MOUNT SERIES:

Performance Characteristics

27327 & 27328 Series - Axial Load vs. Deflection

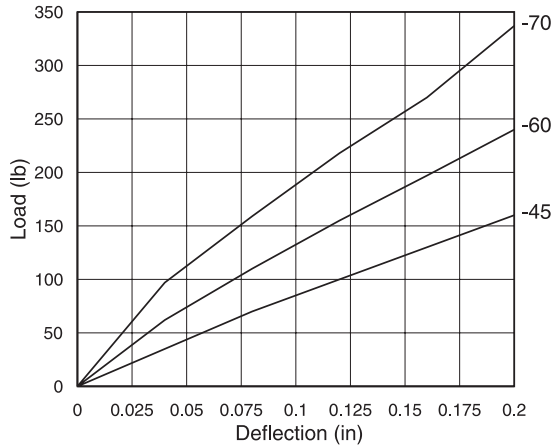

27327 & 27328 Series - Radial Load vs. Deflection

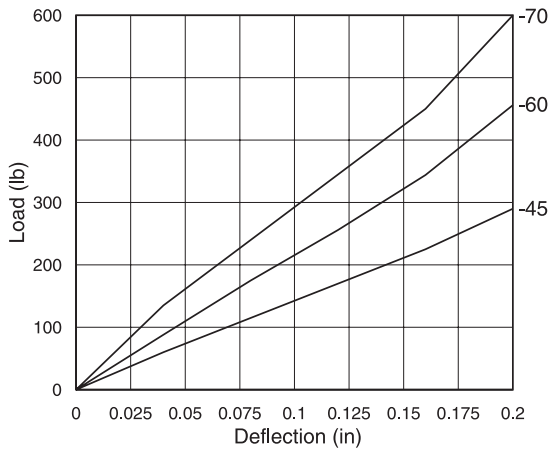

26749 & 27595 Series - Radial Load vs. Deflection

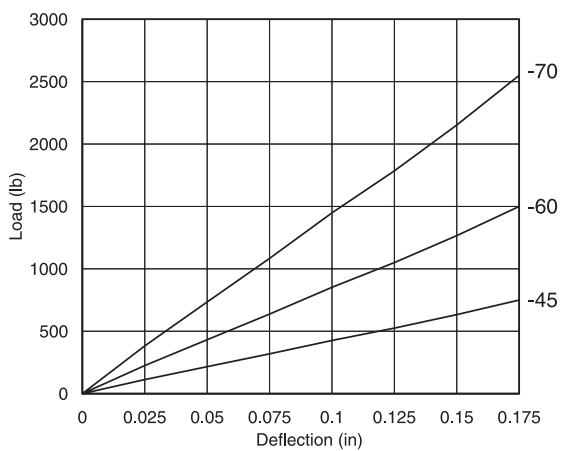

26748 Series - Axial Load vs. Deflection

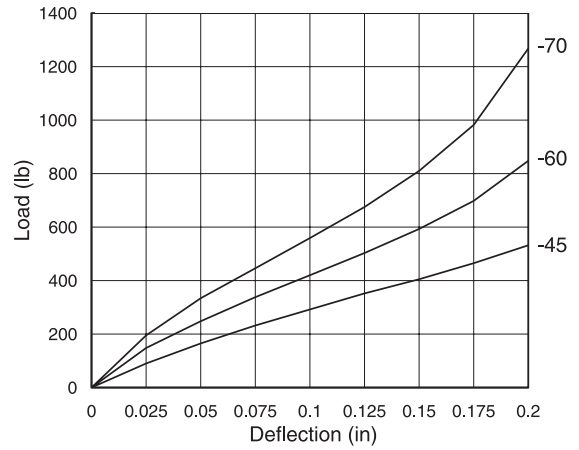

26748 Series - Radial Load vs. Deflection

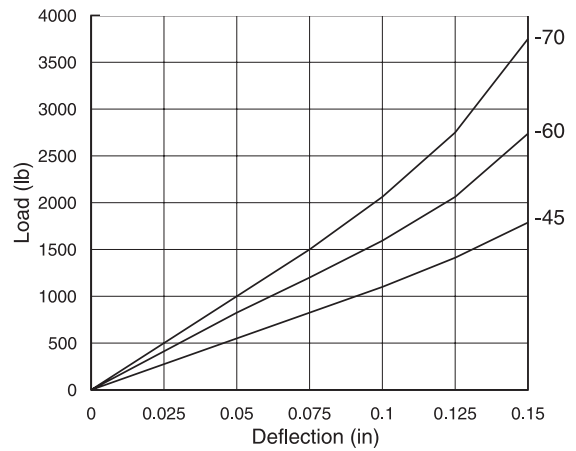

26749 & 27595 Series - Axial Load vs. Deflection

