

# TTB MOUNT SERIES

Mid-frequency, low profile, high deflection mounts for protection from severe vibration and shock.

## APPLICATIONS

- Shipping containers
- Airborne electronics & racking
- Shipboard equipment
- Mobile mounted equipment
- Other applications where high amplitude, low frequency vibration is present

## FEATURES

- Available in Silicone or Neoprene
- Axial to radial stiffness of 2.3:1
- Mid frequency isolation
- Aluminum construction

## BENEFITS

- Attenuates a 15g, 11 millisecond half-sine shock to 10g's
- Attenuates a 30g, 11 millisecond half-sine crash safety shock to 16 g's
- Lightweight

## LOAD RANGE

- 3 load ratings to 30 lbs. per mount

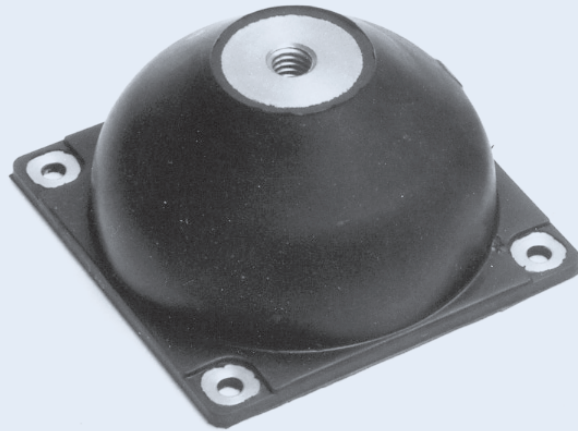

Barry TT-B Mounts are mid-frequency isolators with a large deflection capacity, designed to give both shock and vibration isolation protection. The standard Neoprene version is for applications where temperature extremes are not a factor.

## Specifications

• Natural Frequency	25-35 Hertz
• Transmissibility at resonance	4.0 Max. (Hi-Damp Silicone) 10.0 Max. (Neoprene)
• Resilient Element	Hi-Damp Silicone or Neoprene
• Standard Materials	Aluminum (Restraining Strap Beryllium Copper)
• Weight	6.5 oz.

## Environmental Data

- Hi-Damp Silicone operating temperature range is -67°F to +300°F (-55°C to +150°C) and is resistant to fungus and ozone.
- Neoprene operating temperature range is -20°F to +180°F (-30°C to +82°C) and is resistant to oil and ozone.

# TTB MOUNT SERIES:

## Dimensions & Performance Characteristics

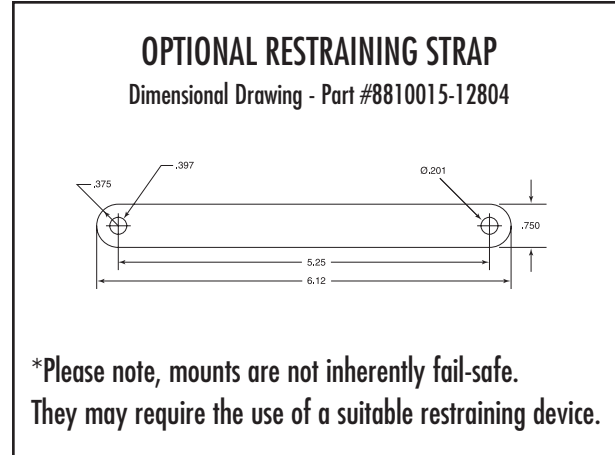
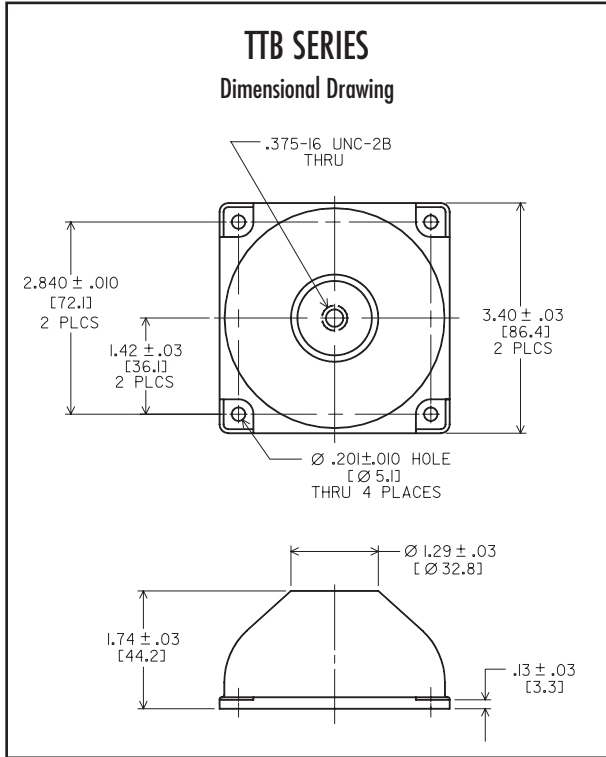

ORDERING INFORMATION			
PART #		LOAD RANGE (lbs.)	
Neoprene	Silicone	Neoprene	Silicone
TTN-B-1	TT-B-1	12	10
TTN-B-2	TT-B-2	20	18
TTN-B-3	TT-B-3	30	25

